

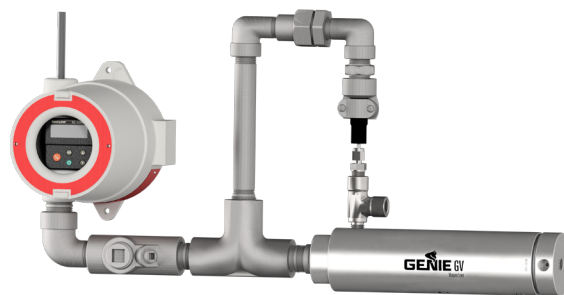

Five times more heat transfer capacity than vaporizing regulators!

Typical vaporizing pressure regulators do not provide the conditions required for proper liquid sample vaporization when a high volume or flow of vaporized sample is required. This is due to their lack of flash vaporization capability and insufficient heat exchange capacity. The Model GV Genie® Vaporizer has five times more heat transfer capacity than current vaporizing regulators and is designed for instantaneous flash vaporization of liquid sample streams that require more heat transfer capacity than conventional vaporizing regulators can supply. For example, the GV can provide up to 23 liters per minute of vaporized propane at 110 VAC.

The design of the vaporizer allows liquid sample to be maintained below its bubble point pressure and temperature until it enters the flash chamber where it is instantaneously vaporized. Heat for vaporization is transferred from an electrical cartridge heater to a low volume flash chamber having a very large heat transfer surface area. The flash chamber is designed to maintain a homogenous vaporized sample. Heat is distributed evenly throughout the flash chamber, resulting in longer heater life and efficient vaporization without partial fractionation of the sample components. The net result is a uniform, homogenous vaporized sample that is representative of the liquid sample composition.



Product Brief

Applications

- Vaporizing liquid sample streams in any process industry when a high volume or flow of vaporized sample is required
 - Petrochemical plants
 - Refineries
 - Natural Gas - LNG & NGLs

Benefits

- Delivers a homogenous vaporized flow rate representative of the liquid sample
- Excellent temperature control
- No premature flashing or partial fractionation
- Installation flexibility
- Fail-safe with max temperature of 338°F

Features

- High capacity electrical cartridge heater
- Discrete hot and cold zones
- Continuous liquid bypass
- Versatile conduit and bypass connections
- Proportional temperature controller
 - Digital temperature readout
 - Backup thermal cutoff

Technical Specifications

Maximum pressure rating	3,000 psig (206.8 Bar) at -40-300°F (-40-149°C)
Temperature control range	95-300°F (35-150 °C) The vaporizer temperature is factory set at 300°F (149°C).
Backup thermal cutoff	Opens at 338°F (170°C)
Internal volume	40cc
Port sizes	1/4" female NPT
Conduit connection	3/4" female NPT
Electrical approval	CSA Certified Assembly: File # 235766 Protection Type: Class 1, Division 1, Groups B, C & D, Temp Code T3 Ambient temperature: -0.4°F (-18°C) to 149°F (65°C)
Power requirements	110/240 VAC, 47-63 Hz
Power output	375 W @ 110 VAC 1,500 W @ 240 VAC
Wetted materials	Machined parts: 316/316L stainless steel / NACE compliant All other metal parts: stainless steel / NACE compliant Sealing material: Fluoroelastomer (other materials available upon request)



Model Numbering & Additional Part Numbers

Your model number is determined by your specific needs. Choose options below.

Sealing material

0 = Fluoroelastomer

1 = Perfluoroelastomer

(other materials available upon request)

How to build the model number:



Dimensions

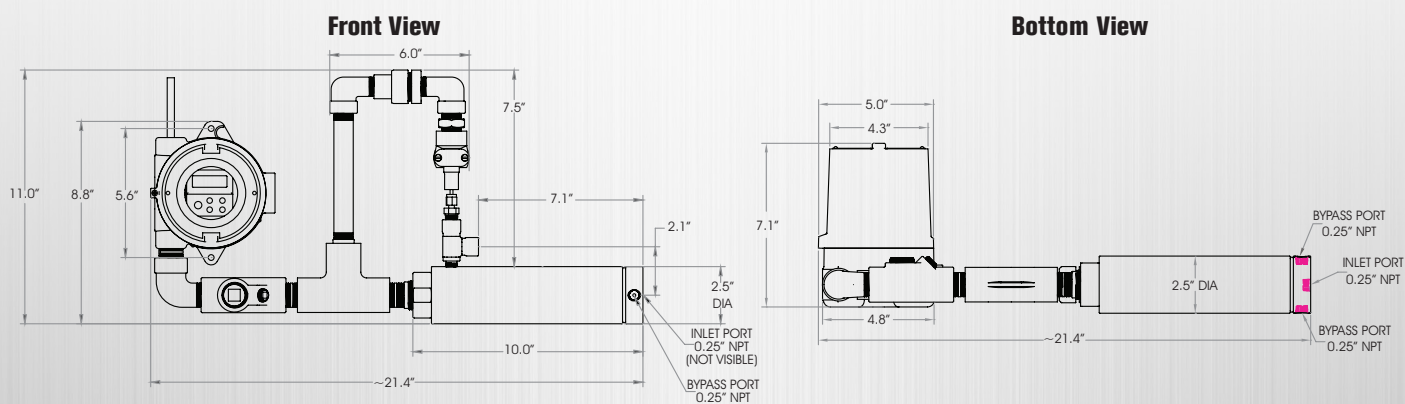

DASTEC S.R.L.

Representantes / Distribuidores Exclusivos

Argentina

Tel: (+54 11) 5352 2500

Email: info@dastecsrl.com.ar

Web: www.dastecsrl.com.ar

A+ Corporation is the leader in Analytically Correct™ Sample Extraction and Conditioning Systems.

Contact us for expert product application assistance.

sales@geniefilters.com > 225.644.5255 > Fax 225.644.3975

41041 Black Bayou Road, Gonzales, LA 70737 An ISO 9001:2008 Certified Company

Genie®, GV®, are trademarks or registered trademarks of A+ Corporation, LLC. All other referenced trademarks are the property of their respective owners.
© 2012 A+ Corporation. All rights reserved. SCC-GV-PS_081919